

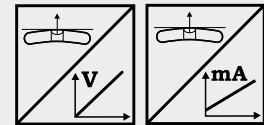

Analog Inclination Sensor for 1 axis or 2 axes in MEMS technology

- Measurement range $\pm 180^\circ$ for 1 axis or $\pm 60^\circ$ for 2 axes
- Protection class IP67 / IP69K
- Analog output linear
- Aluminium housing
- Wear free, high resolution
- High shock resistance
- Servo flange mounting



| Specifications | Output | U2 | Voltage 0.5 ... 10 V / $U_B = 18 \dots 36$ V |
|----------------|-----------------------------|----|--|
| | | | U8 |
| | | I1 | Current 4 ... 20 mA / $U_B = 18 \dots 36$ V, 10 ... 36 V |
| | Measurement range | | $\pm 15 \dots \pm 180^\circ$ for 1 axis or $\pm 60^\circ$ for 2 axes |
| | Resolution | | 0.05° |
| | Linearity | | $\pm 0.5^\circ$ |
| | Settling time | | 0.1 s ... 10 s / 90 %, configurable |
| | Protection class | | IP67/IP69K (connector output with IP69K connector cable) |
| | Material | | Aluminium |
| | Connection | | 5 pin connector M12 axial or radial |
| | Shock (non-operational) | | EN60068-2-27:1993, 100 g/11 ms, 100 shocks |
| | Vibration (non-operational) | | EN60068-2-6:1995, 20 g/10 Hz-2 kHz, 10 cycles |
| | EMC, temperature | | Refer to output specification |

Order code PTAM2

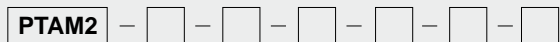

Model name

Axis of inclination

- 1 = Inclination in X axis (mounting X) $\leq \pm 180^\circ$
- 2 = Inclination in X and Y axis (mounting XY) $\leq \pm 60^\circ$

Measuring range [in °]

- 15 ... 180 = $\pm 15^\circ \dots \pm 180^\circ$ in increments of 15°

Output

- U2 = 0.5 ... 10 V
- U8 = 0.5 ... 4,5 V
- I1 = 4 ... 20 mA

Characteristic

- CW = Increasing signal for CW inclination
- CCW = Increasing signal for CCW inclination

Output delay 0 ... 90 %

- Tx.x = 0.1 s ... 10 s

Connection

- M12R5 = 5-pin socket M12, radial (compatible with 4 pin mating connector)
- M12A5 = 5-pin socket M12, axial (compatible with 4 pin mating connector)

Order code connector cable (see page 10)

KAB-...M-M12/4F/G-LITZE

Order example: PTAM2 - 1 - 180 - I1 - CW - T1.0 - M12R5



Digital Inclination Sensor with 1 or 2 axes in MEMS technology

- Measurement range $\pm 180^\circ$ for 1 axis or $\pm 60^\circ$ for 2 axes
- Protection class IP67 / IP69K
- CANopen output
- Aluminium housing
- Wear free, high resolution
- High shock resistance
- Servo flange mounting

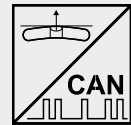

| Specifications | | |
|-----------------------------|--|--|
| Output | | CANopen (profile „Inclination Sensor“) |
| Measurement range | | $\pm 180^\circ$ for 1 axis or $\pm 60^\circ$ for 2 axes |
| Resolution | | 0.05 ° |
| Linearity | | $\pm 0.5^\circ$ |
| Settling time | | 0.1 s ... 10 s / 90%, configurable |
| Protection class | | IP67/IP69K (connector output with IP69K connector cable) |
| Material | | Aluminium |
| Connection | | 5 pin connector M12 axial or radial |
| Shock (non-operational) | | EN60068-2-27:1993, 100 g/11 ms, 100 shocks |
| Vibration (non-operational) | | EN60068-2-6:1995, 20 g/10 Hz-2 kHz, 10 cycles |
| EMC, temperature | | Refer to output specification |

Order code PTDM2

Model name

Output

- CANOP = CANopen
- CANJ1939 = CAN SAE J1939

Connection

- M12R5/CAN = 5-pin socket M12, radial
- M12A5/CAN = 5-pin socket M12, axial

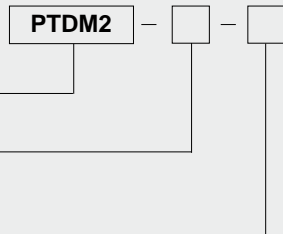

Order code connector cable (see page 11)

KAB - XM - M12/5F/G - M12/5M/G - CAN

Order example: PTDM2 - CANOP - M12R5/CAN

POSITILT®
PTAM2/PTDM2
Dimensions



Outline drawing
M12 radial

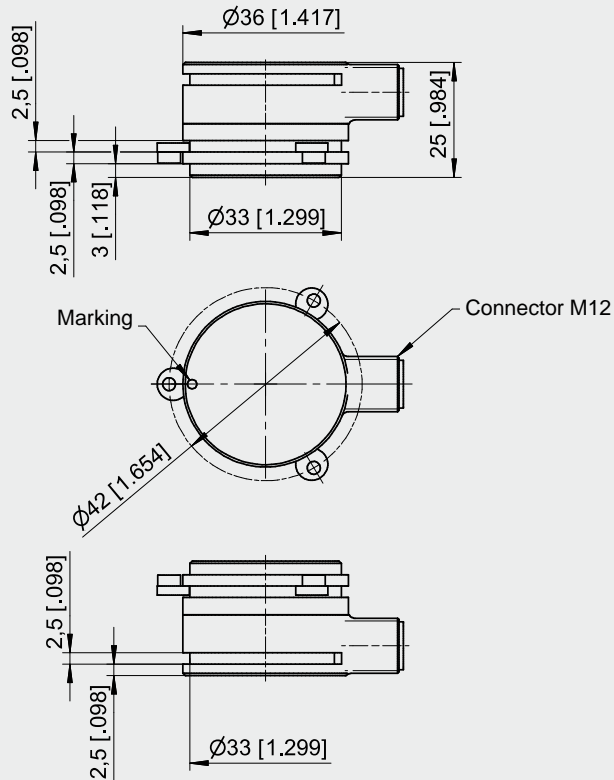

Dimensions in mm [inch]

Dimensions informative only.
 For guaranteed dimensions consult factory.

Outline drawing
M12 axial

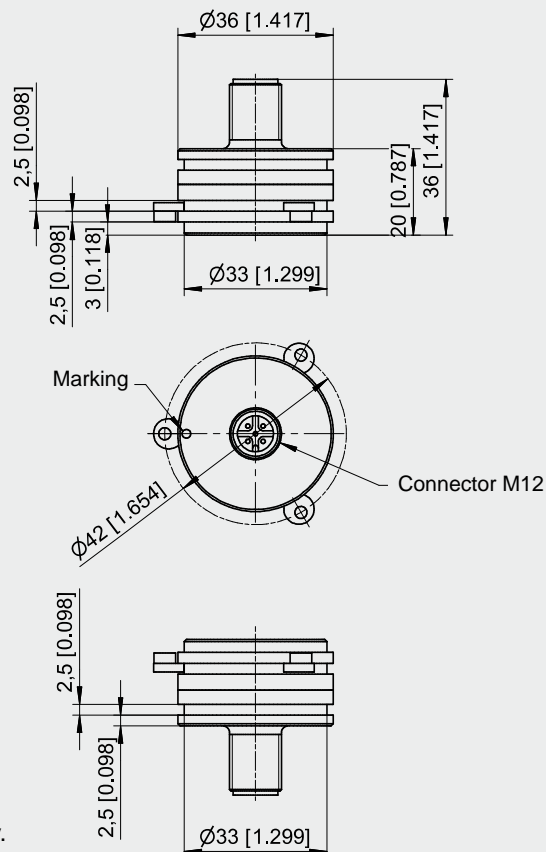

Dimensions in mm [inch]

Dimensions informative only.
 For guaranteed dimensions consult factory.

POSITILT®
PTAM2/PTDM2
Dimensions



Orientation of the
inclination axes

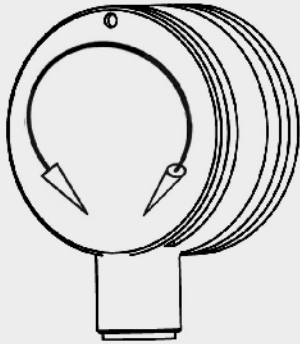

1 axis

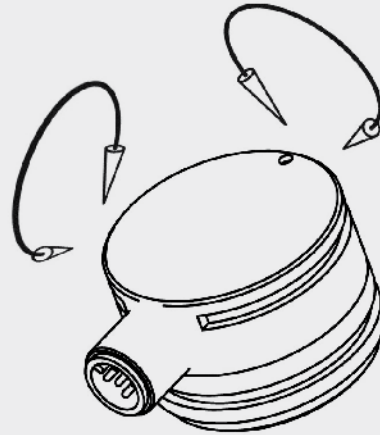

2 axes

| | | |
|---|-------------------------|---|
| U2 Voltage Output 0.5 ... 10 V | Excitation voltage | 18 ... 36 V DC |
| | Excitation current | 12 mA typ., 16 mA max. |
| | Output voltage | 0.5 ... 10 V DC |
| | Output current | 2 mA max. |
| | Measuring rate | 1 kHz standard |
| | Stability (temperature) | $\pm 100 \times 10^{-6} / ^\circ\text{C}$ f.s. (typ.) |
| | Operating temperature | -40 ... +85 °C |
| | Protection | Reverse polarity, short circuit |
| EMC | EN61326-1:2006 | |
| U6 Voltage Output 0.5 ... 4.5 V DC | Excitation voltage | 5V DC $\pm 10\%$ |
| | Excitation current | 16 mA typ., 20 mA max. |
| | Output voltage | 0.5 ... 4.5 V DC |
| | Output current | 2 mA max. |
| | Measuring rate | 1 kHz standard |
| | Stability (temperature) | $\pm 100 \times 10^{-6} / ^\circ\text{C}$ f.s. (typ.) |
| | Operating temperature | -40 ... +85 °C |
| | Protection | Reverse polarity, short circuit |
| EMC | EN61326-1:2006 | |
| U8 Voltage output 0.5 ... 4.5 V | Excitation voltage | 10 ... 36 V DC |
| | Excitation current | 12 mA typ., 16 mA max. |
| | Output voltage | 0.5 ... 4.5 V DC |
| | Output current | 2 mA max. |
| | Measuring rate | 1 kHz standard |
| | Stability (temperature) | $\pm 100 \times 10^{-6} / ^\circ\text{C}$ f.s. (typ.) |
| | Operating temperature | -40 ... +85 °C |
| | Protection | Reverse polarity, short circuit |
| EMC | EN61326-1:2006 | |
| I1 Current Output 4 ... 20 mA | Excitation voltage | 18 ... 36 V DC; 10 ... 36 V for R<250Ω |
| | Excitation current | 32 mA typ., 36 mA max.. |
| | Load resistor | 500 Ω max. |
| | Output current | 4 ... 20 mA |
| | Measuring rate | 1 kHz standard |
| | Stability (temperature) | $\pm 100 \times 10^{-6} / ^\circ\text{C}$ f.s. (typ.) |
| | Operating temperature | -40 ... +85 °C |
| | Protection | Reverse polarity, short circuit |
| EMC | EN61326-1:2006 | |

Other outputs available on request.

Output signals

Connection

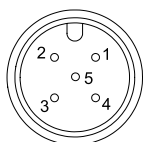

M12A5 / M12R5

View to sensor connector



| Signal Wiring | Output signals | | Connector pin | Cable color |
|---------------|-----------------|-----------------|---------------|-------------|
| | 1 axis | 2 axes | | |
| | Excitation + | Excitation + | 1 | brown |
| | Output X | Output X | 2 | white |
| | GND | GND | 3 | blue |
| | Do not connect! | Output Y | 4 | black |
| | Do not connect! | Do not connect! | 5 | gray |

POSITILT[®] PTDM Output CANopen



Description Inclination sensor with CANopen interface according to CiA 410.

| | | |
|---|-------------------------------------|--|
| CANopen Interface  | Communication profile | CANopen CiA 301 V 4.02, Slave |
| | Device profile | Encoder CiA 410 V 1.2 |
| | Configuration services | LSS, CiA Draft Standard 305 (transmission rate, node ID) |
| | Error Control | Node Guarding, Heartbeat, Emergency Message |
| | Node ID | Adjustable via LSS or via object dictionary, default: 127 |
| | PDO | 1 TxPDO, 0 RxPDO, static mapping |
| | PDO Modes | Event-/Time triggered, Remote-request, Sync cyclic/acyclic |
| | SDO | 1 Server, 0 Client |
| | Certified | Yes |
| | Transmission rate | 50 kBaud to 1 MBaud, adjustable via LSS or via object dictionary, default: 125 kBaud |
| | Bus connection | M12 connector, 5 pin |
| | Integrated bus terminating resistor | Optional |
| | Bus, galvanic isolation | No |

| | | |
|-----------------------|-------------------------|--|
| Specifications | Excitation voltage | 8 ... 36 V DC |
| | Excitation current | 15/30 mA typical for 24/12 V, 100 mA max. |
| | Measuring rate | 1 kHz standard |
| | Stability (temperature) | $\pm 100 \times 10^{-6} / ^\circ\text{C}$ f.s. |
| | Repeatability | 1 LSB |
| | Operating temperature | -40 ... +85 °C |
| | Protection | Reverse polarity, short circuit |
| | EMC | EN61326-1:2006 |

POSITILT[®]

PTDM

Output CAN SAE J1939



Description Inclination sensor according to standard SAE J1939. Configuration of operating parameters by proprietary-A-Message (peer-to-peer connection). Process data exchange by proprietary-B-Message (broadcast).

| Interface J1939  | CAN specification | ISO 11898, Basic and Full CAN 2.0 B |
|---|-------------------------------|-------------------------------------|
| | Transceiver | 24V-compliant, not isolated |
| | Communication profile | SAE J1939 |
| | Baud rate | 250 kbit/s |
| | Internal termination resistor | 120 Ω |
| | Address | Default 247d, configurable |

| NAME Fields | Arbitrary address capable | 1 | Yes |
|--------------------|---------------------------|-------------|----------------------|
| | Industry group | 0 | Global |
| | Vehicle system | 7Fh (127d) | Non specific |
| | Vehicle system instance | 0 | |
| | Function | FFh (255d) | Non specific |
| | Function instance | 0 | |
| | ECU instance | 0 | |
| | Manufacturer | 145h (325d) | Manufacturer ID |
| | Identity number | 0nnn | Serial number 21 bit |

| Parameter Group Numbers (PGN) | Configuration data | PGN EF00h | Proprietary-A (PDU1 peer-to-peer) |
|--------------------------------------|--------------------|-----------|--|
| | Process data | PGN FFnnh | Proprietary-B (PDU2 broadcast); nn Group Extension (PS) configurable |

| Specifications | Excitation voltage | 8 ... 36 V DC |
|-----------------------|-------------------------|---|
| | Excitation current | 15/30 mA typical for 24/12 V, 100 mA max. |
| | Measuring rate | 1 kHz standard |
| | Stability (temperature) | ±100 x 10 ⁻⁶ / °C f.s. |
| | Repeatability | 1 LSB |
| | Operating temperature | -40 ... +85 °C |
| | Protection | Reverse polarity, short circuit |
| | EMC | EN61326-1:2006 |

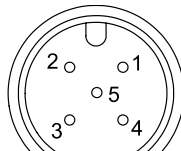
| Signal wiring / connection | Signal name | Connector pin | View to sensor connector  |
|-----------------------------------|--------------|---------------|---|
| | Shield | 1 | |
| | Excitation + | 2 | |
| | GND | 3 | |
| | CAN-H | 4 | |
| | CAN-L | 5 | |

POSITILT® Accessories Mounting Plates



PRPT-BPL1

(screw mounting)
For PTAM2 / PTDM2

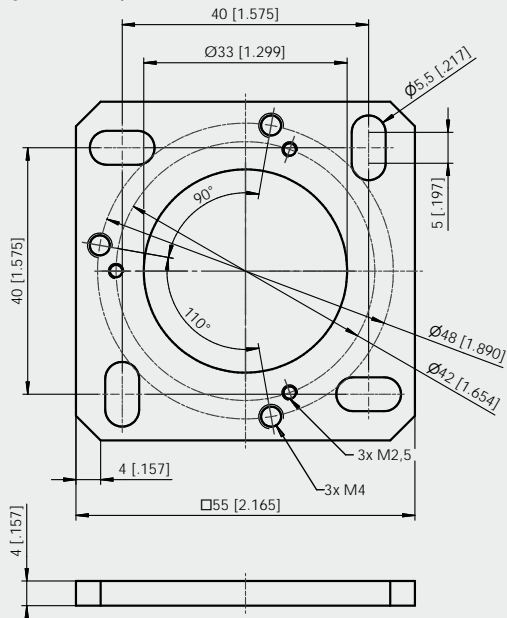

PRPT-BPL2

(welding assembly)
For PTAM2 / PTDM2

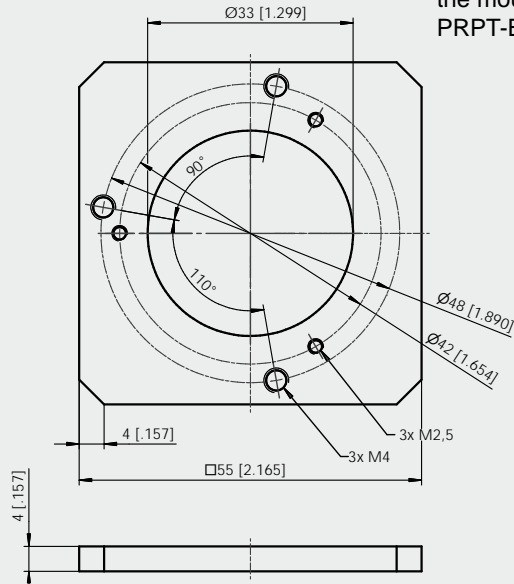

In combination with the mounting clamps PRPT-BFS1 (3 x M2.5) or in combination with the mounting brackets PRPT-BFS2 (3 x M4)

Dimensions in mm [inch]

Weight 30 g approx.

Dimensions informative only.

For guaranteed dimensions please consult factory.

Mounting possibilities PTAM2/PTDM2

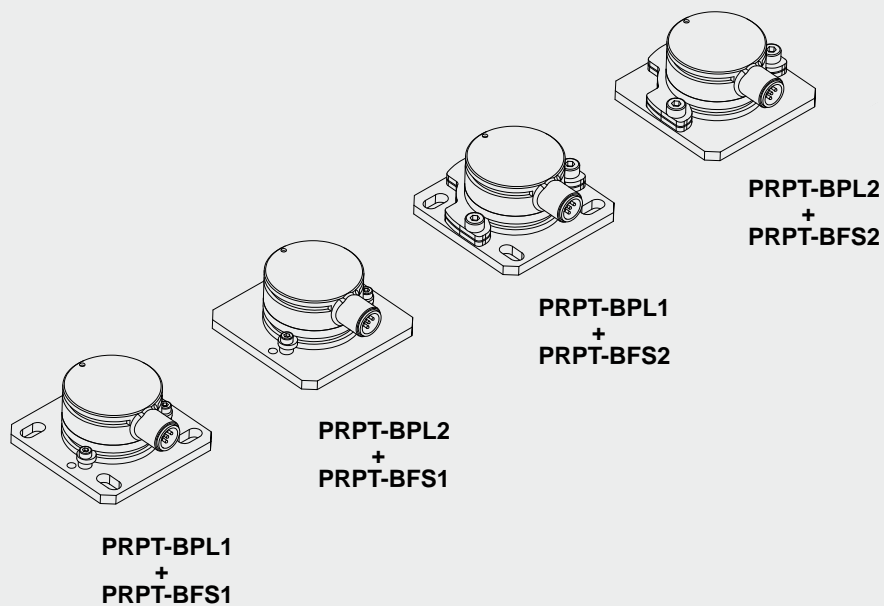

POSITILT[®]
PTAM/PTDM
Characteristic of the linear output



Output signal

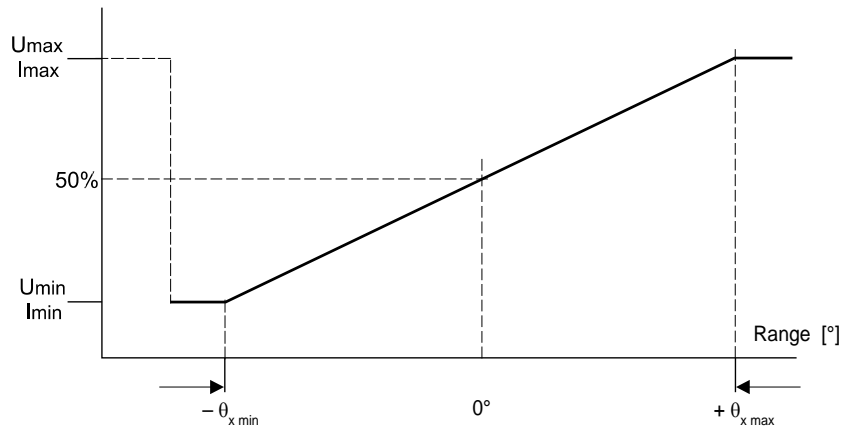

PTAM2/PTDM2

Radial, 1 axis

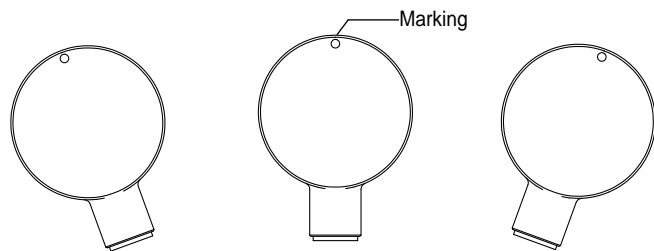

PTAM2/PTDM2

Radial, 2 axes

X

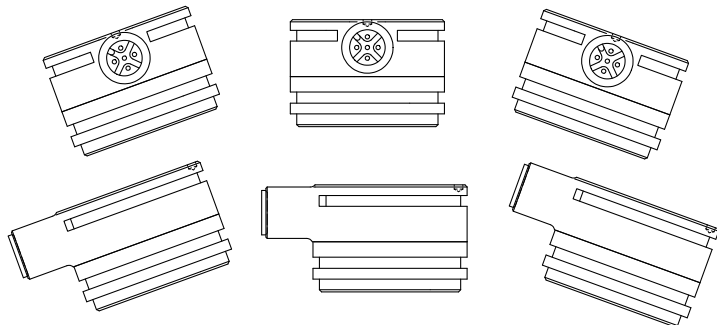

Y

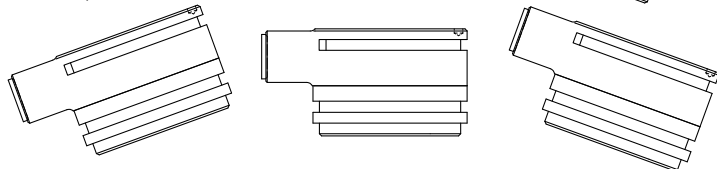

PTAM2/PTDM2

Axial, 1 axis

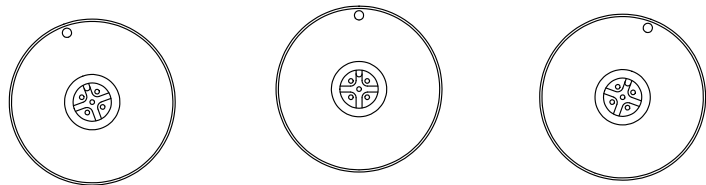

PTAM2/PTDM2

Axial, 2 axes

X

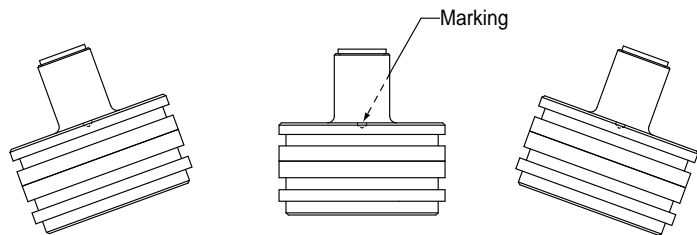

Y

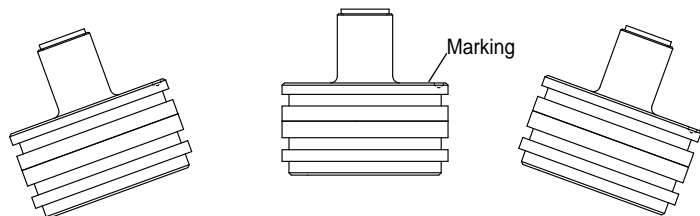

Connector cable for POSIROT®-POSITILT® sensors
4 pins M12

Suitable for 5-pin sensor connectors M12A5 and M12R5

The 4-core screened cable is supplied with a mating 4-pin 90° M12 connector at one end and 4 wires at the other end. Available lengths are 2, 5 and 10 m.

Order code:

KAB - XM - M12/4F/W - LITZE

IP69K: **KAB - XM - M12/4F/W/69K - LITZE**

Length in m

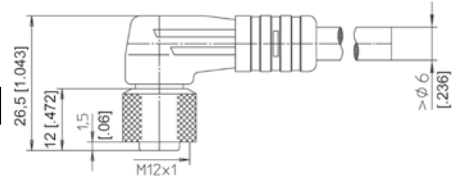
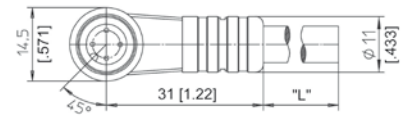

Connector cable for POSIROT®-POSITILT® sensors
4 pins M12

Suitable for 5-pin sensor connectors M12A5 and M12R5

The 4-core screened cable is supplied with a mating 4-pin M12 connector at one end and 4 wires at the other end. Available lengths are 2, 5 and 10 m.

Order code:

KAB - XM - M12/4F/G - LITZE

IP69K: **KAB - XM - M12/4F/G/69K - LITZE**

Length in m

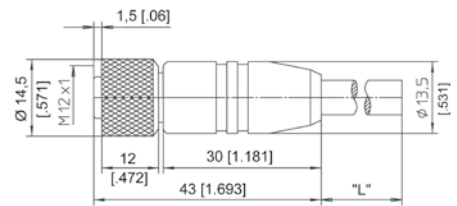

| Signal wiring M12, 4 pin | Connector pin / cable color | | | |
|-----------------------------|-----------------------------|-------|------|-------|
| | 1 | 2 | 3 | 4 |
| | Brown | White | Blue | Black |

Connector cable for POSIROT®-POSITILT® sensors
8 pins M12

The 8-core screened cable is supplied with a mating 8-pin 90° M12 connector at one end and 8 wires at the other end. Available lengths are 2, 5 and 10 m.

Order code:

KAB - XM - M12/8F/W - LITZE

IP69K: **KAB - XM - M12/8F/W/69K - LITZE**

Length in m

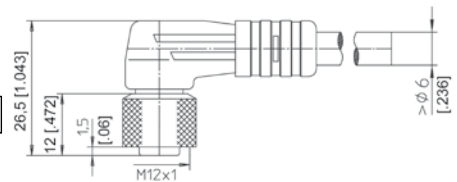
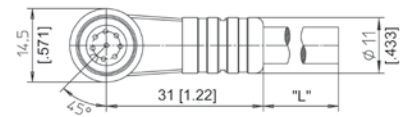

Connector cable for POSIROT®-POSITILT® sensors
8 pins M12

The 8-core screened cable is supplied with a mating 8-pin M12 connector at one end and 8 wires at the other end. Available lengths are 2, 5 and 10 m.

Order code:

KAB - XM - M12/8F/G - LITZE

IP69K: **KAB - XM - M12/8F/G/69K - LITZE**

Length in m

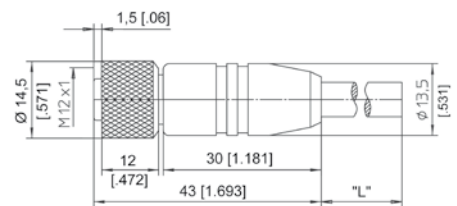

| Signal wiring M12, 8 pin | Connector pin / cable color | | | | | | | |
|-----------------------------|-----------------------------|-------|-------|--------|------|------|------|-----|
| | 1 | 2 | 3 | 4 | 5 | 6 | 7 | 8 |
| | White | Brown | Green | Yellow | Grey | Pink | Blue | Red |

**Connector/bus cable
for POSIROT®-
POSITILT® sensors**
5 pin M12
CAN bus

The 5-lead shielded cable is supplied with a female 5-pin M12 connector at one end and a male 5-pin M12 connector at the other end. Available lengths are 2, 5 and 10 m.

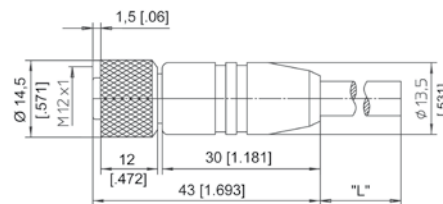

Order code:

KAB - XM - M12/5F/G - M12/5M/G - CAN

IP69K: KAB - XM - M12/5F/G/69K - M12/5M/G/69K - CAN

Length in m

T-piece for bus cable
5 pin M12
CAN bus

Order code:

KAB - TCONN - M12/5M - 2M12/5F - CAN



**Terminating
resistance**
5 pin M12
CAN bus

Order code:

KAB - RTERM - M12/5M/G - CAN

