

High Precision Pressure Transmitter

AE-SHP SERIE

Main features

- Scalable measuring ranges from 0...10 mbar to 0...2000 bar
- Output signals 4...20 mA, 0...10 V, 0...5 V, digital and others
- Resetting and new zero adjustment
- Precision 0.15 % (optional 0.1 %)

Applications

- General industrial applications
- Hydraulics
- Pneumatics
- Test stands
- Mechanical engineering
- Medical engineering

Description

This SHP has been designed for challenging tasks of measuring and control. It has a total error of typically 0.1% (max. 0.15%) under RT referential conditions. By means of a contact controlled by a solenoid, the zero point of a transmitter allows for subsequent adjustment in order to correct errors caused by drift or the installation position, for example.

With the SHP-P version, various parameters of the transmitter can be altered by means of a handheld device or the PC. Apart from scaling the measuring range at a ratio of 4:1, it can also be shifted, which permits a transmitter of a nominal range of 0 to 10 bar to be set at a measuring range of 1 to 4 bar. Also the measuring rate and type of output filter, the characteristic curve (inverting, taking the root, or as a free characteristic curve on 11 nodes) and, in a wide range, the output signal can be adjusted.

Its robust design guarantees a high level of reliability and safety, also in rugged conditions. Its stainless steel diaphragm is fully vacuum-tight, extremely burst-resistant and applicable with all standard media in hydraulics, pneumatics, etc., as long as they are compatible with stainless steel.



Specifications

Pressure range

Silicon technology

Measuring range*	p [mbar]	10	16	20	25	40	60	100	250	600	1000
Overload pressure	p [mbar]	300	300	300	300	300	300	300	300	300	300
Burst pressure	p [mbar]	500	500	500	500	500	500	500	500	500	500

Stainless steel diaphragm

Measuring range*	p [bar]	1,6	2,0	2,5	4,0	6,0	10,0	16,0			
Overload pressure	p [bar]	6	6	6	10	20	20	40			
Burst pressure	p [bar]	9	9	9	15	30	30	60			
Measuring range*	p [bar]	20	25	40	60	100	160	200			
Overload pressure	p [bar]	40	100	100	200	200	400	400			
Burst pressure	p [bar]	60	150	150	300	300	600	600			
Measuring range*	p [bar]	250	400	600	1000	1600	2000				
Overload pressure	p [bar]	750	750	840	1200	2400	2400	(vacuum, relative pressure, + -			
Burst pressure	p [bar]	1000	1000	1050	1500	3000	3000	or absolute pressure are available)			

Electrical parameter	signal	U_s [V _{dc}]	R_i [k Ω]	RA [Ω]
Output signal * and maximum acceptable burden	R_A in Ohm	4...20 mA (2-wire, 3-wire)	9...32	acc. to $R_A = (U_s - 10V) / 0,02 A$
Response time * (10-90%)	t [ms]	0...10 V _{dc} (3-wire)	12...32	> 5,0
Withstand voltage	U [V _{dc}]	4	10...4000	
EMC characteristics		33		
		EN61000-4-2	level 3 & 4	
		EN61000-4-4	level 4	
		EN61000-4-5	level 3	
		EN61000-4-6	level 3	
	EN61000-4-16	level 3		

Accuracy

Accuracy @RT	% of the range	$\leq 0,15^{**}$	option $\leq 0,1$	** incl. nonlinearity, hysteresis, repeatability, zero-offset- and final-offset (acc. to IEC 61298-2)
	BFSL	$\leq 0,05$		
Non-linearity	% of the range	$\leq 0,05$		
Repeatability	% of the range	$\leq 0,00$		
Stability/year	% of the range	$\leq 0,10$		

Acceptable temperature ranges

Measuring medium	T [°C]	-20...85
Ambience	T [°C]	-20...85
Storage	T [°C]	-40...105
Compensated range*	T [°C]	-10...80
Total error	% of the range	-40°C 0,50%
	% of the range	85°C 0,50%

Mechanical parameter

Parts in contact with the measuring medium*		stainless steel, silicon
Housing*		stainless steel
Shock resistance	g	1000 acc. to IEC 68-2-32
Vibration resistance	g	20 acc. to IEC 68-2-6 and IEC 68-2-36
Mass	m [g]	~ 120 (depending on design)
CE - conformity		EC Directive 89/336/EWG
IP system of protection		The IP system of protection as specified in the data sheets generally applies, with their mating plug connected. Relative pressure transmitters usually require a ventilated mating plug and/or cable to allow for pressure compensation. From a pressure range of 60bar, a ventilated mating plug and/or cable is not necessarily required.
* other upon request		

Configurations -examples-

SHP with MVS/A

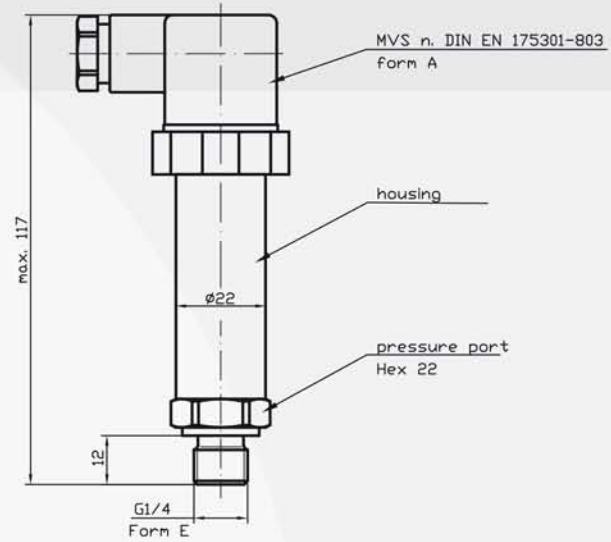

Connectors*

male socket
M12x1 (S 763)

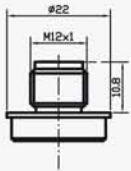

cable output

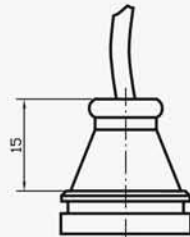

MVS/A
DIN EN 175301-803

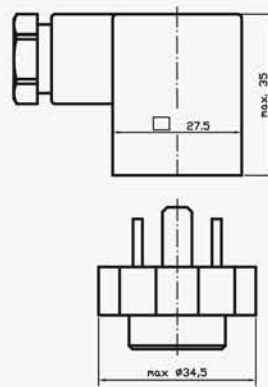

MVS/C
DIN EN 175301-803

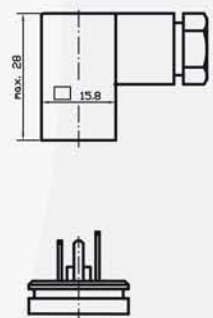

Pressure Connections*

G 1/4 A; DIN 3852; Form E

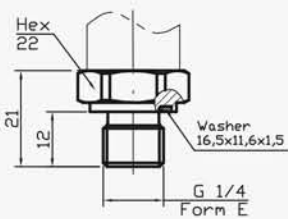

G 1/4 B

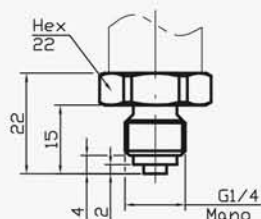

G 1/2 B

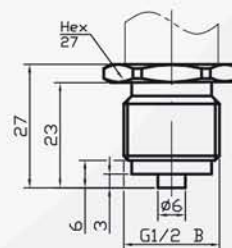

1/4 NPT

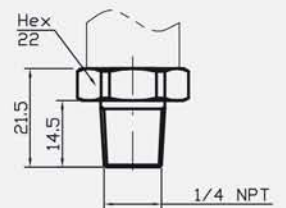

* custom-made adjustments acc. to pressure connections and connecting options are possible

AE-SHP SERIE

High Precision
Pressure Transmitter

Electrical Connections* (left: 2-wire, right: 3-wire)

MVS/A
DIN EN
175301-803

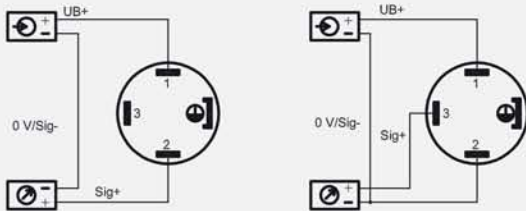

male
socket
M12x1
(S 763)

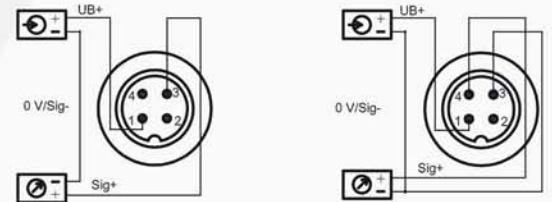

MVS/C
DIN EN
175301-803

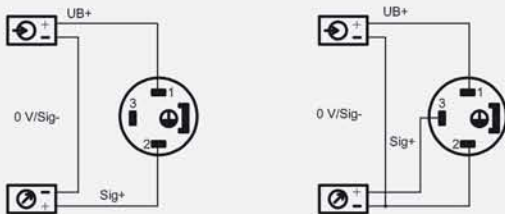

cable
output

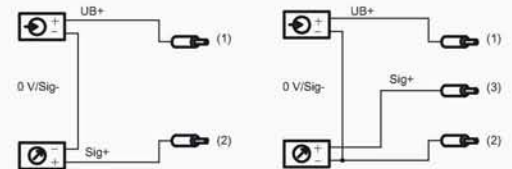

Legend

power supply
 consumer

red
 black
 white

* custom-made adjustments acc. to pressure connections and connecting options are possible

Product line

DS4	Electronic Pressure Switch	SMC	Pressure Transmitter with CANopen Interface
DPSX9I	Intrinsically Safe Electronic Pressure Switch for Current	SME	Pressure Transmitter in Miniature Design
DPSX9U	Intrinsically Safe Electronic Pressure Switch for Voltage	SMF	Pressure Transmitter with Flush Diaphragm
PS1	Level Sensor	SMH	High Pressure Transmitter
PSX2	Intrinsically Safe Level Sensor	SML	Pressure Transmitter for Industrial Application
SHP	High Precision Pressure Transmitter	SMO	Pressure Transmitter in Mobile Hydraulics
SIS	Low Pressure Transmitter in Short and Compact Design	SMS	OEM Pressure Transmitter for Hydraulics and Pneumatics
SIL	Low Pressure Transmitter for Industrial Application	SMX	Intrinsically Safe Pressure Transmitter for Industrial Application
SKE	High Temperature Pressure Transmitter with Detached Electronics	TPS	Multi-Function Transmitter for Pressure and Temperature
SKL	High Temperature Pressure Transmitter with Cooling Fins		