

# TCM 1550 Series Coriolis Mass Flow Meter

## Advantages:

- > Robust for long life
- > Customized installation length
- > Excellent repeatability
- > Option for 345 bar (5,000 psi)

## Benefits:

- > Increased productivity
- > Considerable cost savings for installation
- > Increased product quality
- > Accurate chemical injection metering

**Pressure Rating:** 200 bar, 2,900 psi

## Specifications:

Mass Flow Rate (max.): 1,550 kg/h, 57 lb/min  
 Volumetric Flow Rate (max.): 1,550 l/h, 6.82 gpm, 234 bbl/d (US)  
 Nominal Meter Size: DN6, 1/4"

## Accuracy [liquids]:<sup>1)</sup>

Basic Accuracy [Mass Flow]:  $\pm 0.1$  % of flow rate  
 Mass Flow Repeatability:  $\pm 0.05$  % of flow rate  
 Basic Accuracy [Volume Flow]:  $\pm 0.15$  % of flow rate  
 Volume Flow Repeatability:  $\pm 0.05$  % of flow rate  
 Zero Stability:  $\pm 0.01$  % of full scale

## Accuracy [gases]:

Basic Accuracy [Mass flow]:  $\pm 0.5$  % of flow rate  
 Mass Flow Repeatability:  $\pm 0.25$  % of flow rate

## Density:

Density Range: up to 2,500 kg/m<sup>3</sup>, 2.5 g/cm<sup>3</sup>  
 Density Accuracy: Liquids  $\pm 1.0$  kg/m<sup>3</sup>,  $\pm 0.001$  g/cm<sup>3</sup>  
 Density Repeatability:  $\pm 0.5$  kg/m<sup>3</sup>,  $\pm 0.0005$  g/cm<sup>3</sup>

## Temperature:

Process Temperature Range: Standard: -40 °F ... +212 °F (-40 °C ... +100 °C)  
 Optional: -76 °F ... +392 °F (-60 °C ... +200 °C)  
 Temperature Accuracy:  $\pm 1.8$  °F  $\pm 0.5$  % of reading  
 ( $\pm 1$  °C  $\pm 0.5$  % of reading)  
 Temperature Repeatability:  $\pm 0.36$  °F ( $\pm 0.2$  °C)

## Materials of Construction [wetted parts]:

Tubes: 1.4404/AISI 316L  
 Case: 1.4404/AISI 316L  
 Flow Splitter: 1.4404/AISI 316L  
 Brazing Alloy: BNI-2

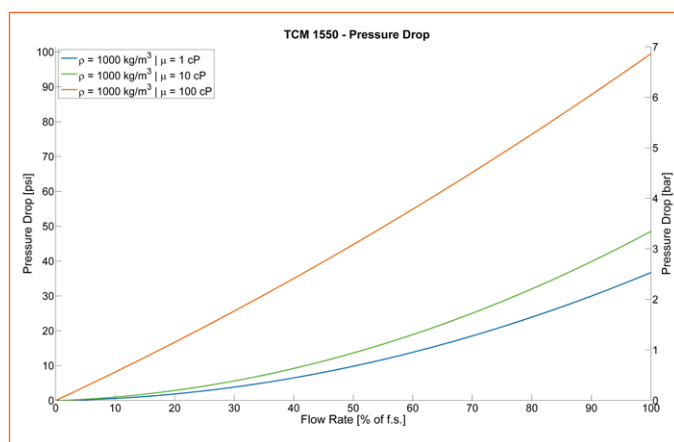

<sup>1)</sup> Stated flow accuracy combines the effects of repeatability, linearity and hysteresis.

## Meter Dimensions:<sup>2)</sup>

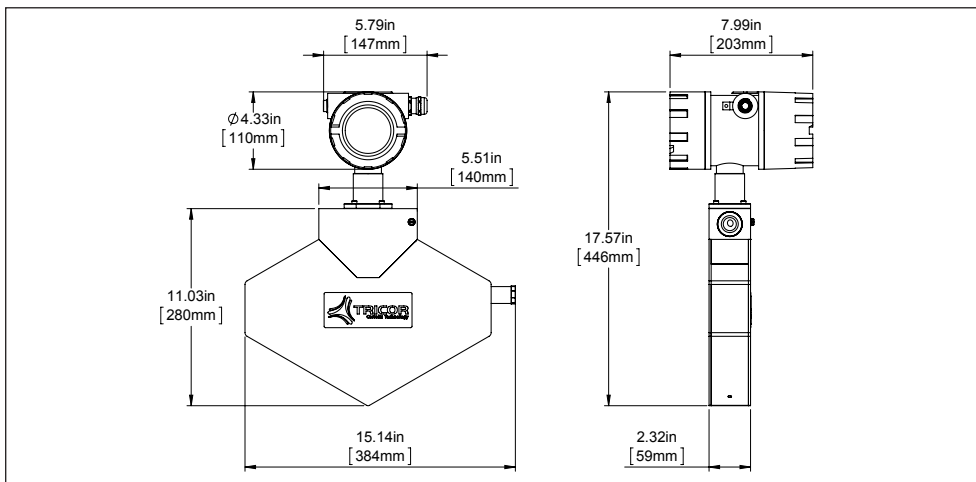

### Compact Version

weight: 11.6 kg/25.7 lb  
with meter mount ex-electronics  
with aluminum diecast housing  
meter connection: G1/2" thread

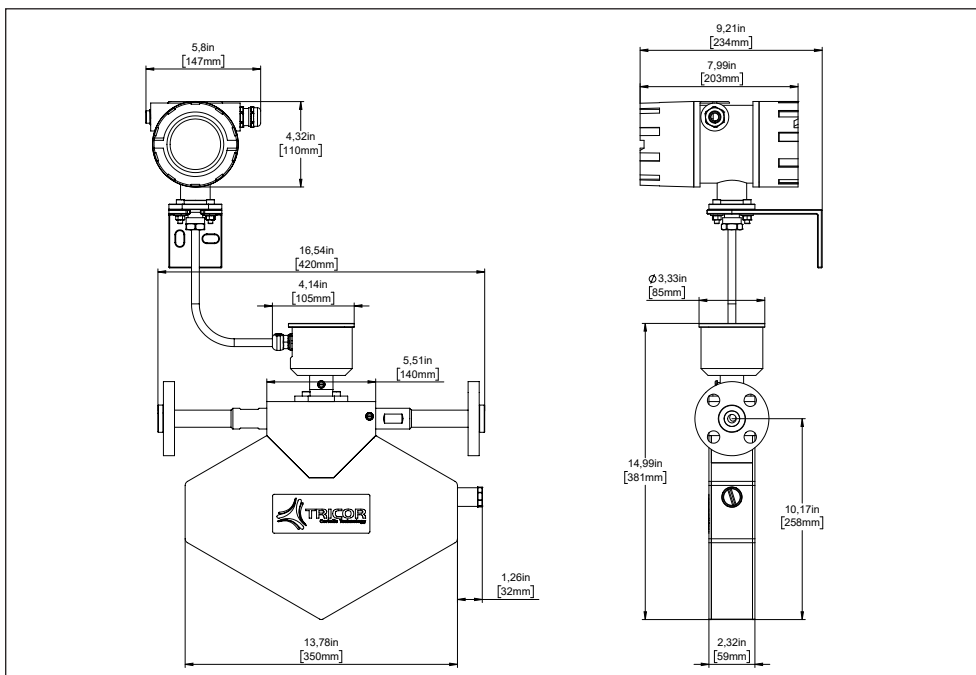

### Remote Version

weight: 12.9 kg/28.5 lb  
with junction box & remote field mount  
meter connection:  
depending on selected connection

## Electronics:

The TCE 8000 transmitter offered with the TRICOR Coriolis Mass Flow Meter is also available with other mounting options.

## Ex Certifications:

ATEX (Ex)	Zone 1: Group IIC or IIB, T2...T4
ATEX (Exn)	Zone 2: II 3G Ex nA IIC T2...T4 Gc
IECEX (Ex)	Zone 1: Group IIC or IIB, T2...T4
cCSAus (Ex1) <sup>5)</sup>	Class 1, Division 1: Group A, B, C, D or C, D, T2...T4
ATEX + IECEX + cCSAus triple approval (Ex3) <sup>5)</sup> <sup>6)</sup>	Zone 1: Group IIC or IIB, T2...T4 and Class 1, Division 1: Group A, B, C, D or C, D, T2...T4
EAC (TR-CU) <sup>5)</sup>	Group IIC or IIB, T2 ... T4

## Panel Mount<sup>3)</sup>



Power Supply:  
Outputs:  
Interface:  
More options on request

## Remote Field Mount<sup>4)</sup>



24 V DC  $\pm$ 20 % or 90 ... 264 V AC  
Analog, Frequency, Pulse, Status  
RS485 RTU (Modbus), HART®

<sup>2)</sup> Drawing of the Meter Dimensions reflects one standard connection, other connections on request (Installation length can vary depending on selected connection).

<sup>3)</sup> Weight: 0.4 kg/0.88 lb.

<sup>4)</sup> Weight with aluminum diecast housing: 3.8 kg/8.3 lb with 3 m cable, Weight with 1.4404/AISI 316L housing: 6.15 kg/13.56 lb.

<sup>5)</sup> For Ex1, Ex3, EAC (TR-CU) the electronic is only available in aluminum housing.

<sup>6)</sup> Only with remote electronics.