

Ultrasonic Distance Sensor
 Ultraschall Abstandssensor
 Capteurs Ultrasoniques

P53-150-D30-PNO-CM12
 Artikelnr. / code nr.: 517078



Technical Data	Technische Daten	Données techniques	
Max. sensing distance	Max. Reichweite	Portée	1500 mm
Min. sensing distance	Min. Reichweite	Distance minimale	150 mm
Switching frequency	Schaltfrequenz	Fréquence de commutation	7 Hz
Hysteresis	Hysteresis	Hystérésis	1%
Repeatability	Wiederholgenauigkeit	Répétabilité	0,2 % / 2mm
Beam angle	Schallkeule	Angle de faisceau	8 °
Temperature range	Temperaturbereich	Température de service	-15 ... +70 °C
Temperature compensation	Temperaturkompensation	Compensation en température	Yes/Ja/Oui
Operating voltage	Betriebsspannung	Tension de service	24 Vdc ± 20%
Current consumption	Stromaufnahme	Courant consommé	<40 mA
Output	Ausgang	Sortie	PNP NO
Max. output current	Max. Ausgangsstrom	Courant sortie max.	500 mA
Stainless steel housing	Edelstahlgehäuse	Boîtier inox	1.4571 D30
Sealing	Schutzart	Étanchéité	IP68
Connector	Steckeranschluß	Connexion connecteur	M12 x1

Valid for room temperature / Gültig für Raumtemperatur / Valable pour température ambiante de 25°C

Accessories	Zubehör	Accessoires	
Connector with 2 m cable straight	Kabeldose 2m gerade	Connecteur femelle droit, câble 2 m	P66195214-001
Connector with 2 m cable angled	Kabeldose 2m gewinkelt	Connecteur femelle coudé, câble 2 m	P66195216-001
Mating connector straight	Kabeldose gerade	Connecteur femelle exécution droite	P66195044-001
Mating connector angled	Kabeldose gewinkelt	Connecteur femelle exécution coudée	P66195045-001
Mounting clamp	Befestigungsschelle	Collier de fixation	P43178389-030

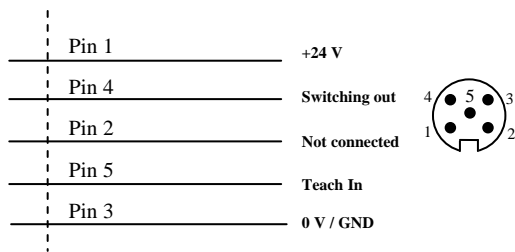

Wiring/Anschlüsse/Raccordement électrique

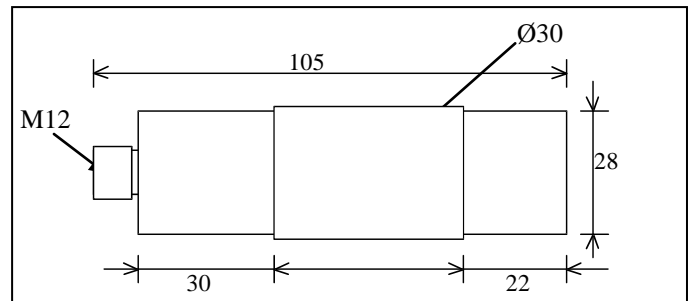

Dimensions/ Abmessungen/ Dimensions mm

Detection range / Erfassungsbereich/ Plage de détection mm

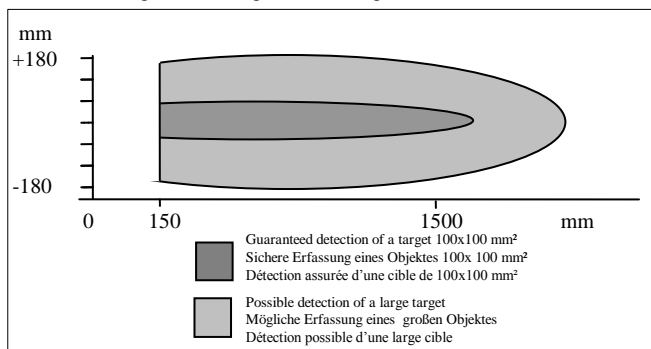

DS53-SD30-PO-S-150

Normal Switching Operation

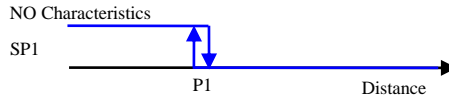

Teach in procedure / Einlernvorgang / Apprentissage

<p><u>Teach in of switching output SP1 at Position P1</u> Move target to position of P1. Connect Teach-In line 2 sec. with GND. Disconnect Teach-In line. P1 is now programmed.</p>	<p><u>Einlernen des Schaltpunktes SP1 an der Stelle P1</u> Objekt in Position des neuen Schaltpunktes bringen. Teach-In mit GND verbinden ca. 2 sec. Verbindung lösen dann ist Schaltpunkt eingelernt.</p>	<p><u>Apprentissage du seuil SP1 a la position P1.</u> Positionnez cible à P1. Connecter Teach-In 2 sec avec GND. Déconnecter Teach-In et SP est programmée.</p>
--	--	--

<p>Warranty/Remedy PIL warrants goods of its manufacture as being free of defective materials and faulty workmanship. If warranted goods are returned to PIL during the period of coverage, PIL will repair or replace without charge those items it finds defective. The foregoing is Buyer's sole remedy and is in lieu of all other warranties, expressed or implied, including those of merchantability and fitness for a particular purpose. Specifications may change without notice. The information we supply is believed to be accurate and reliable as of this printing. However we assume no responsibility for its use. While we provide application assistance personally, through our literature and the PIL web site, it is up to the customer to determine the suitability of the product in the application.</p>	<p>Garantie und Haftungsansprüche PIL garantiert für seine hergestellten Produkte fehlerfreies Material und Qualitätsarbeit. Wenn Produkte innerhalb der Gewährleistungsfrist an PIL zurückgesendet werden, ersetzt oder repariert PIL kostenlos die Teile, die als fehlerhaft angesehen werden. Das Vorangegangene gilt als einzige Entschädigung des Käufers und alle anderen ausdrücklichen oder stillschweigenden Garantien einschließlich Qualitäts- und Sachmängelhaftung. Änderungen der technischen Daten ohne Vorankündigung sind vorbehalten. Die von uns bereitgestellten Informationen halten wir für exakt und zuverlässig, wie bei dieser Druckschrift. Wir übernehmen jedoch keine Haftung für deren Anwendung. Obwohl PIL persönliche und schriftliche Anwendungshilfe sowie Informationen über die PIL Webseite bietet, ist es die Entscheidung des Kunden ob das Produkt sich für die entsprechende Anwendung eignet.</p>	<p>Garantie/ Recours PIL garantit que les articles de sa fabrication sont exempts de défaut de pièces et main d'oeuvre. Si les articles garantis sont retournés à PIL pendant la période de couverture, PIL réparera ou remplacera gratuitement ceux qui auront été trouvés défectueux. Ce qui précède constitue le seul recours de l'acheteur et se substitue à toutes autres garanties explicites ou implicites, y compris celles relatives à la commercialisation ou la compatibilité avec une application particulière. Les caractéristiques techniques peuvent changer sans préavis. Les informations que nous apportons sont présumées précises et fiables au moment de la mise sous presse. Cependant, nous déclinons toute responsabilité quant à leur utilisation. Bien que nous apportions notre aide pour les applications, de façon individuelle, par notre littérature et par le site web PIL, il incombe au client de déterminer si le produit convient à l'application.</p>
---	---	--

<p>!!! WARNING !!! PERSONAL INJURY DO NOT USE these products as safety or emergency stop devices, or in any other application where failure of the product could result in personal injury. Failure to comply with these instructions could result in death or serious injury.</p>	<p>!!! WARNUNG !!! PERSONENSCHADEN Diese Produkte dürfen weder als Sicherheits- oder Not-Abschaltgeräte noch in anderen Anwendungen, bei denen ein Fehler an diesem Produkt zu Personenschaden führen könnte, eingesetzt werden. Missachtung dieser Anweisungen kann zu schweren Verletzungen oder zum Tod führen.</p>	<p>!!! ATTENTION !!! BLESSURES CORPORELLES NE PAS UTILISER ces produits en tant que dispositifs d'arrêt d'urgence ou de sécurité, ni dans aucune autre application où la défaillance du produit pourrait entraîner des blessures corporelles. L'inobservation de ces instructions peut entraîner la mort ou de graves blessures.</p>
--	--	--